



Bybee MUSIC RAILS™

Direct Current Power Conditioners

General Description

The **Bybee Music Rails™** from Bybee Labs are small footprint, active DC power conditioning modules. They are designed to be installed at the terminus of DC linear & switching power supplies.

With their low noise and low impedance, they produce a highly purified source of DC power for any load within their ratings. Signal-on-rail is reduced along with power supply noise. (See noise chart, page 3).

There are two models available in two polarities: 2A +/- and 15A +/- . Only 0.5V is dropped by the 2A device and 2.1V by the 15A device. Any model can be used to clean up the noise floor of switching power supplies to levels representative of the very best analog supplies. In linear supplies, large banks of filter capacitors can be replaced by simple ripple filters, allowing package size to be reduced.

Applications

- High-Fidelity Analog Components
- High-Fidelity Digital Components
- High-Definition Video Components
- Test & Measurement Equipment
- Linear Power Supplies
- Switching Power Supplies
- High-End Car Stereo
- Medical Equipment
- Any other applications where power supply noise & signal-on-rail affects equipment performance

Features

- Low Noise Floor: 20nV/root(Hz)
- Low Output Impedance: 6mΩ typ
- Wide Voltage Range: 4.5–550V
- High Current Range: 0–2A / 0–15A
- Low Dropout Voltage: 0.5V / 2.1V
- Low Dissipation: 1W / 31.5W
- Direct-Coupled Topology
- Small Footprint: 1.7H x 1.5W x 0.4D

Fig. 1 Raw DC Power Supply

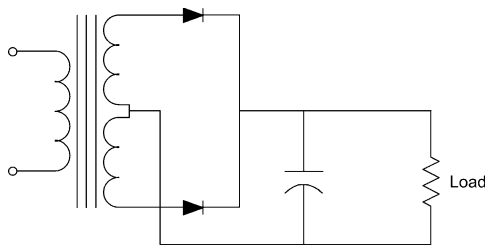

Simplified Stock Power Supply

Fig. 2 Raw Supply + DCPC

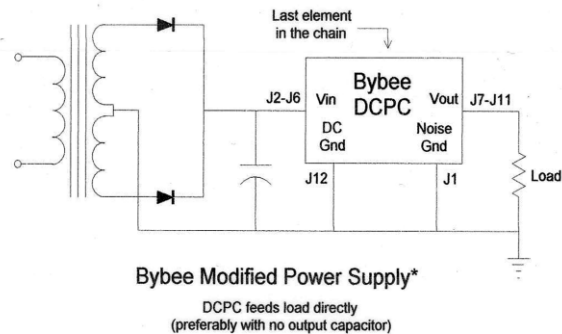

Benefits

In Fig. 2 (above), a MUSIC RAIL module is inserted between the raw power supply and the active circuit. The module now interfaces direct with the active circuit. Signals from circuit stages that share common power supply rails are bypassed by the wideband, low impedance of the MUSIC RAIL. The DC current coming out of the raw supply is at the same time highly filtered by the Module. This dual effect improves the definition of both audio and video signals. The MUSIC RAIL operates safely up to 30V and is adaptable to high-voltage power supplies by the addition of three external parts. See Fig. 5 (below) for high-voltage schematic and page 3 for R1 derating chart.



Performance Characteristics

Parameter	2A Typ	15A Typ
V _{in} min.	V _{out} + dropout	V _{out} + dropout
V _{dropout}	0.5V	2.1V
V _{out}	4.5V min	4.5V min
V _{out} grounded	30V max	30V max
V _{out} floating ¹	550V max	550V max
Quiescent Current	11.5mA	11.5mA
Dissipation	1W max	31.5W max
Load Cap. max ²	10uF	1000uF
Max. Input Ripple	0.3V	1.8V
Noise Suppression	45dB	45dB
Noise Floor	19nV/RtHz	9nV/RtHz

¹ See Fig. 5, below.

² May be increased for light loads.

Installation Notes

1. J1 bypasses noise currents & input ripple to ground.
2. V_{in} must supply 11.5mA idle current to the DCPC circuitry.
3. J12 returns the DCPC idle current to the input source.
4. J1 & J12 may be tied together or run separately to star.
5. J2-J6 (V_{in}) should be ganged together to carry more current.
6. J7-J11 (V_{out}) should be ganged together to carry more current.
7. 15A devices must use appropriate heat sink (Pd = 2.1V * load current).
8. **15A device transistor must be isolated from ground with thermally conductive insulator.**
9. Output capacitor not recommended (see app notes).
10. C1 must withstand the full input voltage with headroom for line surges.

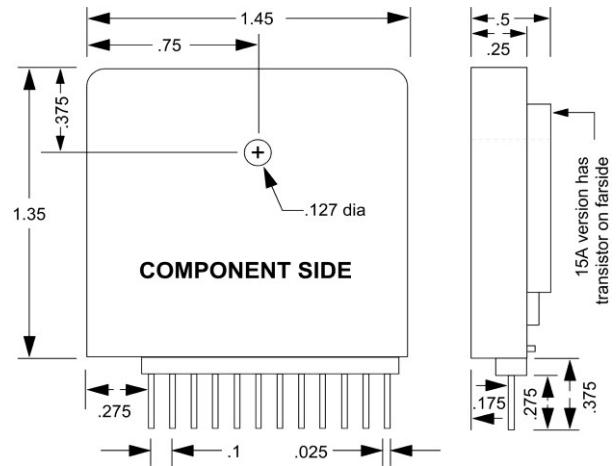

Fig. 3. Dimensions

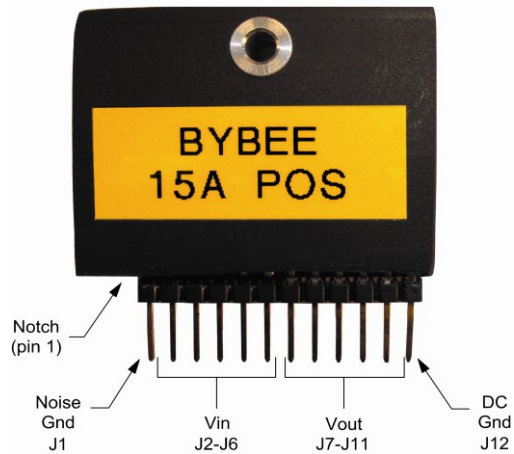

Fig. 4. Hook-up Guide

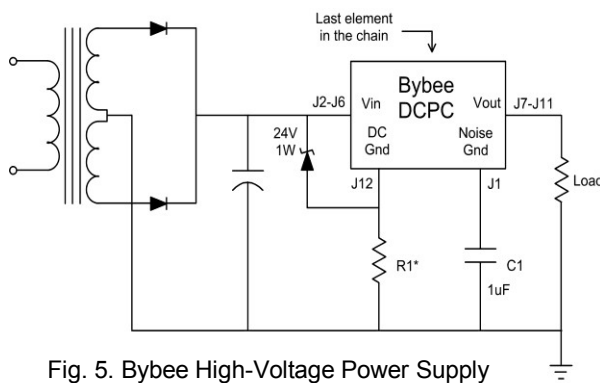

Fig. 5. Bybee High-Voltage Power Supply

$$*R = (V_{in} - 24V) / (.005A + .0115A) \text{ (zener current + DCPC current)}$$

$$*W = (V_{in} - 24V) \times (.005A + .0115A) \times 5 \text{ (formula includes 5X derating factor)}$$

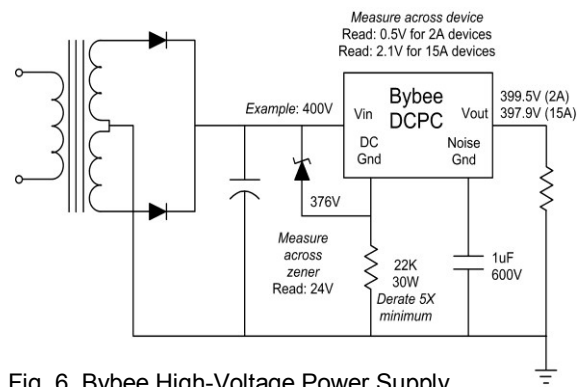
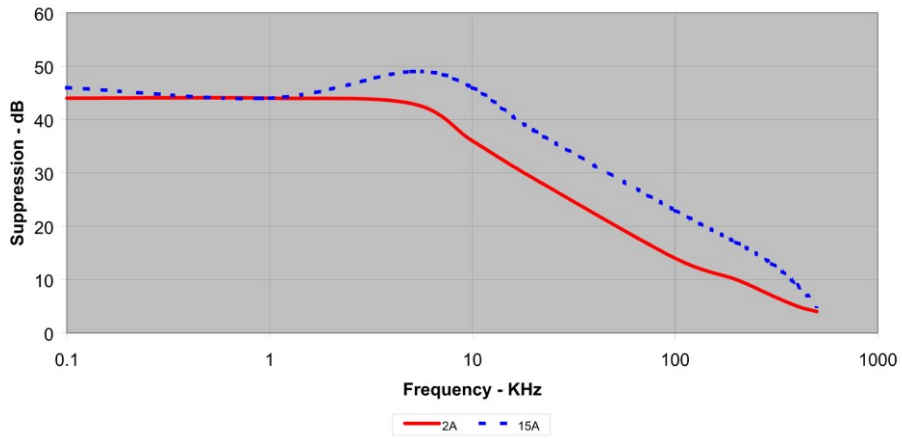

Fig. 6. Bybee High-Voltage Power Supply
Typical Test Voltages

Positive polarity shown. Zener must be reversed for negative Music Rails.



Noise Suppression vs Frequency



Resistance vs Input Voltage, 30V to 150V

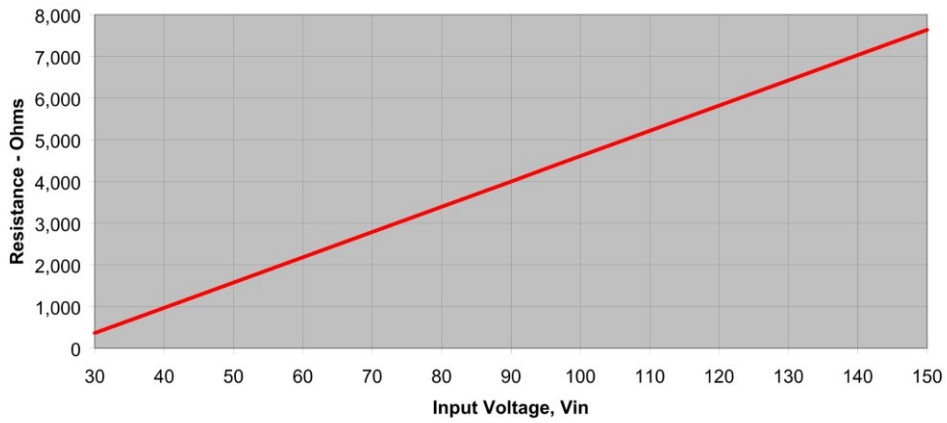

Resistance vs Input Voltage, 150V to 550V

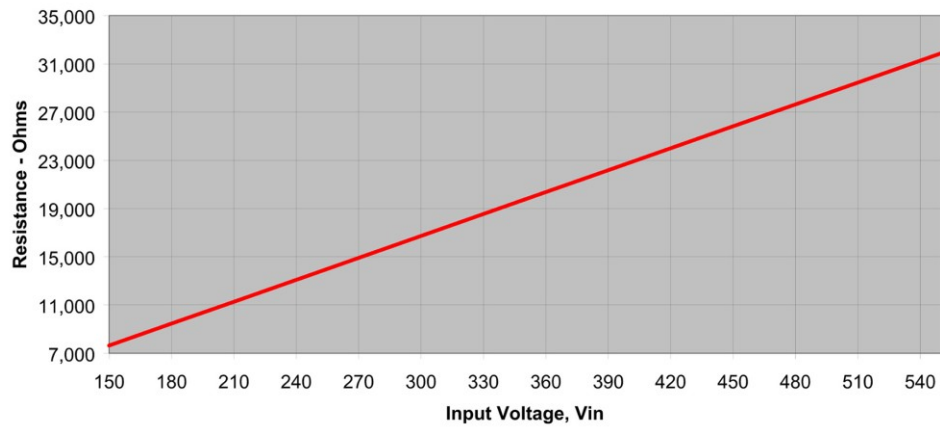



Bybee MUSIC RAILS™ Ordering Information

MODULE TYPE	FAMILY	POLARITY	PART #	PRICE
Bybee Music Rail	2A	Pos	MR2AP	\$55.00
Bybee Music Rail	2A	Neg	MR2AN	\$55.00
Bybee Music Rail	15A	Pos	MR15AP	\$75.00
Bybee Music Rail	15A	Neg	MR15AN	\$75.00
Accessory	Family	Polarity	Part #	Price
High-voltage adaptor kit ¹	Either	Either	HI-VKIT	\$25.00

¹ State rail voltage when ordering high-voltage kits.

Each kit includes the following:

1. One or more 20W resistors optimized for your app.
2. One 24V, 1W zener diode (voltage clamp).
3. One 1uF, 630V polypropylene capacitor (noise drain).
4. Two terminal strips for mounting parts.
5. A schematic showing value(s) of R1 (Fig. 5).
6. Photographs showing typical layouts. (Fig. 7) (Fig. 8)

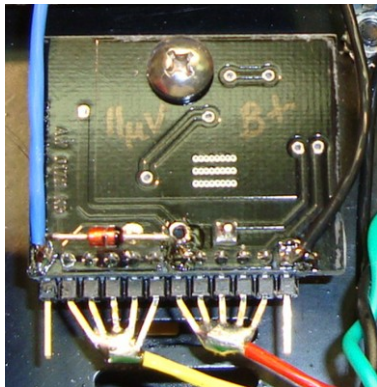

Fig. 7. Diode location on PC board.

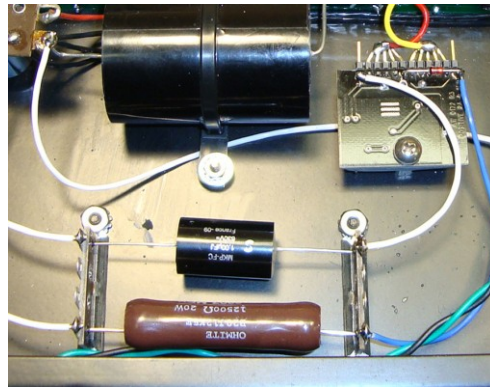

Fig. 8. High-voltage parts mounted & wired.

Bybee Labs, Inc. Information and Ordering

Doug Hall
 480-213-1450
DougHall@BybeeLabs.com
 8390 East Via De Ventura
 Suite F-110
 Scottsdale, AZ 85258

Bybee MUSIC RAILS™
Bybee In – Noise Out!
www.BybeeLabs.com